

JX Threaded Inserts for Plastic Series

With holes Self Tapping Thread Insert JX-204T/JX-205T



Part Number Designation

JX-205-G03- 010- ZI
 Product Code Size Code Material Finish Code

Part Number Designation

JX-204-G03- 010- ZI
 Product Code Size Code Material Finish Code

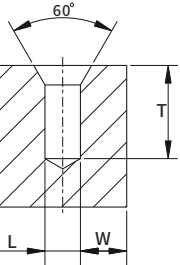
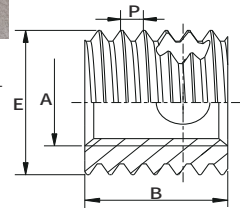

- Application: A perforated insert, a self-tapping fastener, creates the ability to have a high load on low-shear materials, providing a wear-resistant, shock-resistant screw connection. It is suitable for mounting on the following materials: aluminum or aluminum alloy, magnesium aluminum alloy, urea formaldehyde (hard plastic), thermoplastic (with soft thermoplastic with support less than 100ShoreA).
- Material: untempered steel, surface hardened steel, galvanizing, chromium plating, brass, anti-rust material 1.4105, anti-rust materials 1.4305
Tolerance:ISO2768-m
- Margins W: light alloy $\geq 0.2-0.6E$; cast iron $\geq 0.3-0.5E$; plastic $\geq 0.25-0.9E$
- Special applications: applications in detrital sensitive environments (such as electronics), with three closed bore as a clastic storage device.

Material Code Description:

- 1.Non quenched Carbon steel.....010
- 2.Quenched Carbon steel.....020
- 3.Brass.....030
- 4.Antirust Material 1.4105.....040
- 5.Antirust Material 1.4305.....050

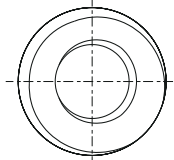

Unit:mm

Part No				Internal Thread	External Thread	Long	Blind hole boring minimum depth	Bore diameter L	
Carbon Steel	Brass	1.4105 Stainless Steel	1.4305 Stainless Steel	A	E	P	B	T	Metal Plastic
JX-204T-G03-010	JX-204T-G03-030	JX-204T-G03-040	JX-204T-G03-050	M3	5	0.6	4	6	Φ4.7-4.8 Φ4.6-4.7
JX-205T-G03-010	JX-205T-G03-030	JX-205T-G03-040	JX-205T-G03-050				6	8	Φ4.7-4.8 Φ4.6-4.7
JX-204T-G3.5-010	JX-204T-G3.5-030	JX-204T-G3.5-040	JX-204T-G3.5-050	M3.5	6	0.8	5	7	Φ5.6-5.7 Φ5.5-5.6
JX-205T-G3.5-010	JX-205T-G3.5-030	JX-205T-G3.5-040	JX-205T-G3.5-050				8	10	Φ5.6-5.7 Φ5.5-5.6
JX-204T-G04-010	JX-204T-G04-030	JX-204T-G04-040	JX-204T-G04-050	M4	6.5	0.8	6	8	Φ6.1-6.2 Φ6.0-6.1
JX-205T-G04-010	JX-205T-G04-030	JX-205T-G04-040	JX-205T-G04-050				8	10	Φ6.1-6.2 Φ6.0-6.1
JX-204T-G05-010	JX-204T-G05-030	JX-204T-G05-040	JX-204T-G05-050	M5	8	1.0	7	9	Φ7.6-7.7 Φ7.4-7.6
JX-205T-G05-010	JX-205T-G05-030	JX-205T-G05-040	JX-205T-G05-050				10	13	Φ7.6-7.7 Φ7.4-7.6
JX-204T-G06-010	JX-204T-G06-030	JX-204T-G06-040	JX-204T-G06-050	M6	10	1.25	8	10	Φ9.5-9.6 Φ9.3-9.5
JX-205T-G06-010	JX-205T-G06-030	JX-205T-G06-040	JX-205T-G06-050				12	15	Φ9.5-9.6 Φ9.3-9.5
JX-204T-G08-010	JX-204T-G08-030	JX-204T-G08-040	JX-204T-G08-050	M8	12	1.5	9	11	Φ11.3-11.5 Φ11.1-11.3
JX-205T-G08-010	JX-205T-G08-030	JX-205T-G08-040	JX-205T-G08-050				14	17	Φ11.3-11.5 Φ11.1-11.3
JX-204T-G10-010	JX-204T-G10-030	JX-204T-G10-040	JX-204T-G10-050	M10	14	1.5	10	13	Φ13.4-13.5 Φ13.1-13.3
JX-205T-G10-010	JX-205T-G10-030	JX-205T-G10-040	JX-205T-G10-050				18	22	Φ13.4-13.5 Φ13.1-13.3
JX-204T-G12-010	JX-204T-G12-030	JX-204T-G12-040	JX-204T-G12-050	M12	16	1.75	12	15	Φ15.2-15.4 Φ15.0-15.2
JX-205T-G12-010	JX-205T-G12-030	JX-205T-G12-040	JX-205T-G12-050				22	26	Φ15.2-15.4 Φ15.0-15.2
JX-204T-G14-010	JX-204T-G14-030	JX-204T-G14-040	JX-204T-G14-050	M14	18	2	14	17	Φ17.2-17.4 Φ17.0-17.2
JX-205T-G14-010	JX-205T-G14-030	JX-205T-G14-040	JX-205T-G14-050				24	28	Φ17.2-17.4 Φ17.0-17.2
JX-204T-G16-010	JX-204T-G16-030	JX-204T-G16-040	JX-204T-G16-050	M16	20	2	14	17	Φ19.2-19.4 Φ19.0-19.2
JX-205T-G16-010	JX-205T-G16-030	JX-205T-G16-040	JX-205T-G16-050				24	28	Φ19.2-19.4 Φ19.0-19.2

JX Threaded Inserts for Plastic Series

Self-tapping inserts with safety grooves JX-206T/JX-207T

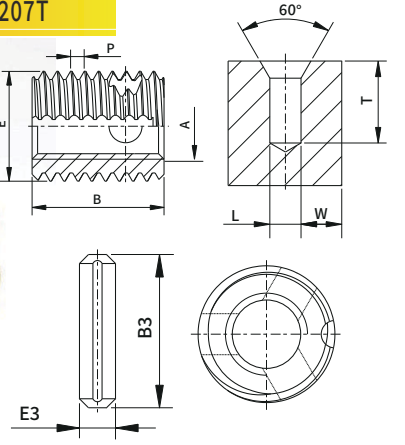

Part Number Designation

JX-207-G04- 010- ZI
 Product Code Size Code Material Finish Code

- Application: This special insert is used to absorb extreme torsional and flutter pressures. The anti-rotation function can be achieved by making a parallel groove and groove on the grooved bolt (pre-drilling a hole with a diameter of E3 and a depth of B3 + 1mm on the workpiece).
- Material: untempered steel, surface hardened steel, galvanizing, chromium plating, brass, anti-rust material 1.4105, anti-rust materials 1.4305
Tolerance:ISO2768-m
- Margins W: light alloy $\geq 0.2-0.6E$; cast iron $\geq 0.3-0.5E$

Material Code Description:

- 1.Non quenched Carbon steel.....010
- 2.Quenched Carbon steel.....020
- 3.Brass.....030
- 4.Antirust Material 1.4105.....040
- 5.Antirust Material 1.4305.....050

Part Number Designation

JX-206-G04- 010- ZI
 Product Code Size Code Material Finish Code

Part No				Internal Thread	External Thread	Long	Blind hole boring minimum depth	Socket screw	Bore diameter
Carbon Steel	Brass	1.4105 Stainless Steel	1.4305 Stainless Steel	A	E	P	B	T	B3 E3 L
JX-206T-G04-010	JX-206T-G04-030	JX-206T-G04-040	JX-206T-G04-050	M4	6.5	0.8	6	8	4 2 Φ6.1-6.2
JX-207T-G04-010	JX-207T-G04-030	JX-207T-G04-040	JX-207T-G04-050				8	10	6 2 Φ6.1-6.2
JX-206T-G05-010	JX-206T-G05-030	JX-206T-G05-040	JX-206T-G05-050	M5	8	1.0	7	9	4 2 Φ7.6-7.7
JX-207T-G05-010	JX-207T-G05-030	JX-207T-G05-040	JX-207T-G05-050				10	13	6 2 Φ7.6-7.7
JX-206T-G06-010	JX-206T-G06-030	JX-206T-G06-040	JX-206T-G06-050	M6	10	1.25	8	10	6 2 Φ9.5-9.6
JX-207T-G06-010	JX-207T-G06-030	JX-207T-G06-040	JX-207T-G06-050				12	15	10 2 Φ9.5-9.6
JX-206T-G08-010	JX-206T-G08-030	JX-206T-G08-040	JX-206T-G08-050	M8	12	1.5	9	11	6 2 Φ11.3-11.5
JX-207T-G08-010	JX-207T-G08-030	JX-207T-G08-040	JX-207T-G08-050				14	17	10 2 Φ11.3-11.5
JX-206T-G10-010	JX-206T-G10-030	JX-206T-G10-040	JX-206T-G10-050	M10	14	1.5	10	13	6 2 Φ13.3-13.5
JX-207T-G10-010	JX-207T-G10-030	JX-207T-G10-040	JX-207T-G10-050				18	22	10 2 Φ13.3-13.5
JX-206T-G12-010	JX-206T-G12-030	JX-206T-G12-040	JX-206T-G12-050	M12	16	1.75	12	15	10 2 Φ15.2-15.4
JX-207T-G12-010	JX-207T-G12-030	JX-207T-G12-040	JX-207T-G12-050				22	26	16 2 Φ15.2-15.4
JX-206T-G14-010	JX-206T-G14-030	JX-206T-G14-040	JX-206T-G14-050	M14	18	2	14	17	10 2 Φ17.2-17.4
JX-207T-G14-010	JX-207T-G14-030	JX-207T-G14-040	JX-207T-G14-050				24	28	16 2 Φ17.2-17.4
JX-206T-G16-010	JX-206T-G16-030	JX-206T-G16-040	JX-206T-G16-050	M16	20	2	14	17	10 2 Φ19.2-19.4
JX-207T-G16-010	JX-207T-G16-030	JX-207T-G16-040	JX-207T-G16-050				24	28	16 2 Φ19.2-19.4

Unit:mm

http://www.juxinfasteners.com

http://www.juxinfasteners.com