

# JX STAMPING FASTENERS SERIES

## JX-Q404 Single coil spring lock washers, Light type

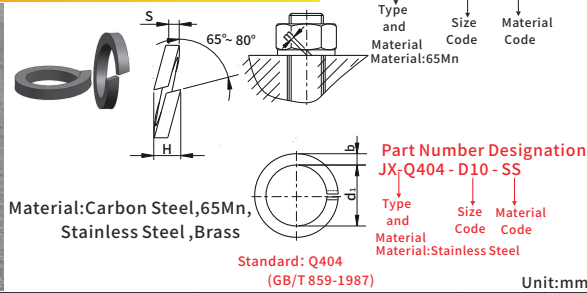

Thread Size D	P/N			d <sub>1</sub>		S			b			H		m
	65Mn	Stainless steel	Brass	max	min	Nom	max	min	Nom	max	min	min	max	
3	JX-Q404-D3-65Mn	JX-Q404-D3-SS	JX-Q404-D3-B	3.4	3.1	0.6	0.68	0.52	1	1.1	0.9	1.2	1.5	0.3
4	JX-Q404-D4-65Mn	JX-Q404-D4-SS	JX-Q404-D4-B	4.4	4.1	0.8	0.90	0.70	1.2	1.3	1.1	1.6	2	0.4
5	JX-Q404-D5-65Mn	JX-Q404-D5-SS	JX-Q404-D5-B	5.4	5.1	1.1	1.2	1	1.5	1.6	1.4	2.2	2.75	0.55
6	JX-Q404-D6-65Mn	JX-Q404-D6-SS	JX-Q404-D6-B	6.68	6.1	1.3	1.4	1.2	2	2.1	1.9	2.6	3.25	0.65
8	JX-Q404-D8-65Mn	JX-Q404-D8-SS	JX-Q404-D8-B	8.68	8.1	1.6	1.7	1.5	2.5	2.65	2.35	3.2	4	0.8
10	JX-Q404-D10-65Mn	JX-Q404-D10-SS	JX-Q404-D10-B	10.9	10.2	2	2.1	1.9	3	3.15	2.85	4	5	1
12	JX-Q404-D12-65Mn	JX-Q404-D12-SS	JX-Q404-D12-B	12.9	12.2	2.5	2.65	2.35	3.5	3.7	3.3	5	6.25	1.25
(14)	JX-Q404-D14-65Mn	JX-Q404-D14-SS	JX-Q404-D14-B	14.9	14.2	3	3.15	2.85	4	4.2	3.8	6	7.5	1.5
16	JX-Q404-D16-65Mn	JX-Q404-D16-SS	JX-Q404-D16-B	16.9	16.2	3.2	3.4	3	4.5	4.7	4.3	6.4	8	1.6
(18)	JX-Q404-D18-65Mn	JX-Q404-D18-SS	JX-Q404-D18-B	19.04	18.2	3.6	3.8	3.4	5	5.2	4.8	7.2	9	1.8
20	JX-Q404-D20-65Mn	JX-Q404-D20-SS	JX-Q404-D20-B	21.04	20.2	4	4.2	3.8	5.5	5.7	5.3	8	10	2
(22)	JX-Q404-D22-65Mn	JX-Q404-D22-SS	JX-Q404-D22-B	23.34	22.5	4.5	4.7	4.3	6	6.2	5.8	9	11.25	2.25
24	JX-Q404-D24-65Mn	JX-Q404-D24-SS	JX-Q404-D24-B	25.5	24.5	5	5.2	4.8	7	7.3	6.7	10	12.5	2.5
(27)	JX-Q404-D27-65Mn	JX-Q404-D27-SS	JX-Q404-D27-B	28.5	27.5	5.5	5.7	5.3	8	8.3	7.7	11	13.75	2.75
30	JX-Q404-D30-65Mn	JX-Q404-D30-SS	JX-Q404-D30-B	31.5	30.5	6	6.2	5.8	9	9.3	8.7	12	15	3

注(Remark): 1)尽可能不采用括号内的规格(Try to avoid the specifications of the brackets); 2)m>0.

## JX-Q405 Heavy-duty spring washers

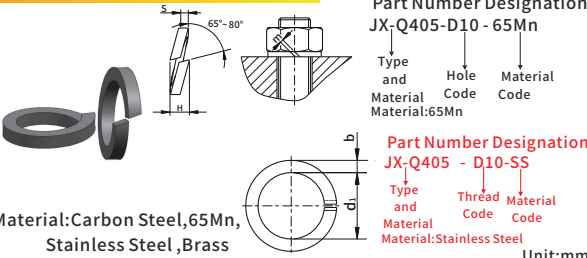

Thread Size D	P/N			d <sub>1</sub>		S			b			H		m
	65Mn	Stainless steel	Brass	max	min	Nom	max	min	Nom	max	min	min	max	
6	JX-Q405-D6-65Mn	JX-Q405-D6-SS	JX-Q405-D6-B	6.68	6.1	1.8	1.95	1.65	2.6	2.75	2.45	3.6	4.5	0.9
8	JX-Q405-D8-65Mn	JX-Q405-D8-SS	JX-Q405-D8-B	8.68	8.1	2.4	2.55	2.25	3.2	3.4	3	4.8	6	1.2
10	JX-Q405-D10-65Mn	JX-Q405-D10-SS	JX-Q405-D10-B	10.9	10.2	3	3.15	2.85	3.8	4	3.6	6	7.5	1.5
12	JX-Q405-D12-65Mn	JX-Q405-D12-SS	JX-Q405-D12-B	12.9	12.2	3.5	3.7	3.3	4.3	4.5	4.1	7	8.75	1.75
(14)	JX-Q405-D14-65Mn	JX-Q405-D14-SS	JX-Q405-D14-B	14.9	14.2	4.1	4.3	3.9	4.8	5	4.6	8.2	10.25	2.05
16	JX-Q405-D16-65Mn	JX-Q405-D16-SS	JX-Q405-D16-B	16.9	16.2	4.8	5	4.6	5.3	5.5	5.1	9.6	12	2.4
(18)	JX-Q405-D18-65Mn	JX-Q405-D18-SS	JX-Q405-D18-B	19.04	18.2	5.3	5.5	5.1	5.8	6	5.6	10.6	13.25	2.65
20	JX-Q405-D20-65Mn	JX-Q405-D20-SS	JX-Q405-D20-B	21.04	20.2	6	6.2	5.8	6.4	6.7	6.1	12	15	3
(22)	JX-Q405-D22-65Mn	JX-Q405-D22-SS	JX-Q405-D22-B	23.34	22.5	6.6	6.9	6.3	7.2	7.5	6.9	13.2	16.5	3.3
24	JX-Q405-D24-65Mn	JX-Q405-D24-SS	JX-Q405-D24-B	25.5	24.5	7.1	7.4	6.8	7.5	7.8	7.2	14.2	17.75	3.55
(27)	JX-Q405-D27-65Mn	JX-Q405-D27-SS	JX-Q405-D27-B	28.5	27.5	8	8.3	7.7	8.5	8.8	8.2	16	20	4
30	JX-Q405-D30-65Mn	JX-Q405-D30-SS	JX-Q405-D30-B	31.5	30.5	9	9.3	8.7	9.3	9.6	9	18	22.5	4.5

Remark: 1)Try to avoid the specifications of the brackets; 2)m>0.

# JX STAMPING FASTENERS SERIES

## JX-Q406 Spring washers for assembly

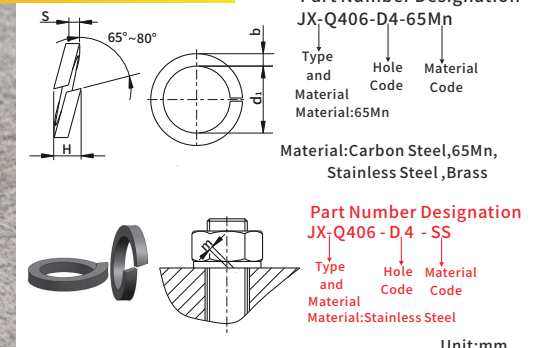

Thread Size D	P/N			d <sub>1</sub>		S			b			H		m
	65Mn	Stainless steel	Brass	max	min	Nom	max	min	Nom	max	min	min	max	
2.5	JX-Q406-D2.5-65Mn	JX-Q406-D2.5-SS	JX-Q406-D2.5-B	2.34	2.20	0.6	0.68	0.52	1	1.1	0.9	1.2	1.5	0.3
3	JX-Q406-D3-65Mn	JX-Q406-D3-SS	JX-Q406-D3-B	2.83	2.69	0.8	0.90	0.7	1.2	1.3	1.1	1.6	2	0.4
4	JX-Q406-D4-65Mn	JX-Q406-D4-SS	JX-Q406-D4-B	3.78	3.6	1.1	1.2	1	1.5	1.6	1.4	2.2	2.75	0.55
5	JX-Q406-D5-65Mn	JX-Q406-D5-SS	JX-Q406-D5-B	4.75	4.45	1.3	1.4	1.2	2	2.1	1.9	2.6	3.25	0.65
6	JX-Q406-D6-65Mn	JX-Q406-D6-SS	JX-Q406-D6-B	5.71	5.41	1.6	1.7	1.5	2.5	2.65	2.35	3.2	4	0.8
8	JX-Q406-D8-65Mn	JX-Q406-D8-SS	JX-Q406-D8-B	7.64	7.28	2	2.1	1.9	3	3.15	2.85	4	5	1
10	JX-Q406-D10-65Mn	JX-Q406-D10-SS	JX-Q406-D10-B	9.59	9.23	2.5	2.65	2.35	3.5	3.7	3.3	5	6.25	1.25
12	JX-Q406-D12-65Mn	JX-Q406-D12-SS	JX-Q406-D12-B	11.53	11.10	3	3.13	2.85	4	4.2	3.8	6	7.5	1.5

## JX-Q407B Plain washers for assembly

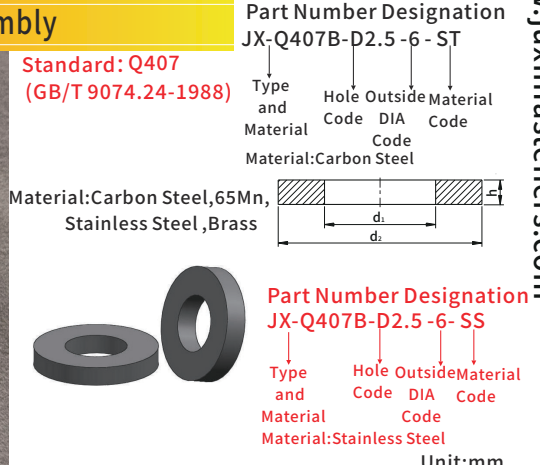

Thread Size D	P/N			d <sub>1</sub>		d <sub>2</sub>		h			
	Carbon Steel	Stainless steel	Brass	max	min	Nom	max	min	Nom	max	min
2.5	JX-Q407B-D2.5-6-ST	JX-Q407B-D2.5-6-SS	JX-Q407B-D2.5-6-B	2.34	2.24	6	6	5.7	0.5	0.55	0.45
3	JX-Q407B-D3-7-ST	JX-Q407B-D3-7-SS	JX-Q407B-D3-7-B	2.83	2.73	7	7	6.64	0.5	0.55	0.45
4	JX-Q407B-D4-9-ST	JX-Q407B-D4-9-SS	JX-Q407B-D4-9-B	3.78	3.66	9	9	8.64	0.8	0.9	0.7
5	JX-Q407B-D5-10-ST	JX-Q407B-D5-10-SS	JX-Q407B-D5-10-B	4.75	4.57	10	10	9.64	1	1.1	0.9
6	JX-Q407B-D6-12-ST	JX-Q407B-D6-12-SS	JX-Q407B-D6-12-B	5.71	5.53	12	12	11.57	1.6	1.8	1.4
8	JX-Q407B-D8-16-ST	JX-Q407B-D8-16-SS	JX-Q407B-D8-16-B	7.64	7.42	16	16	15.57	2	2.2	1.8
10	JX-Q407B-D10-20-ST	JX-Q407B-D10-20-SS	JX-Q407B-D10-20-B	9.59	9.37	20	20	19.48	2.5	2.7	2.3
12	JX-Q407B-D12-24-ST	JX-Q407B-D12-24-SS	JX-Q407B-D12-24-B	11.53	11.26	24	24	23.48	3	3.3	2.7