

AUTOMOTIVE SCREWS FASTENERS SERIES

JX-Q273 Cross recessed large half round head tapping screws

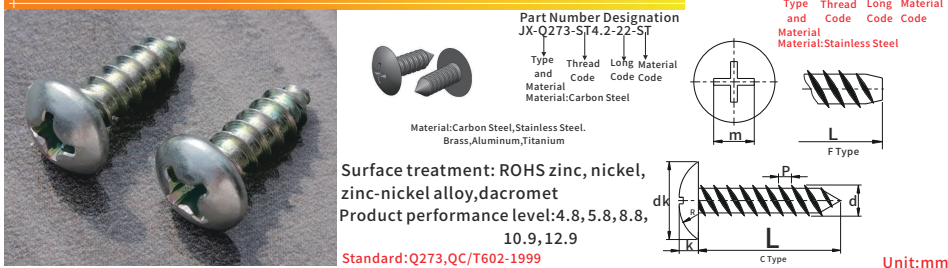

Size d	Pitch P	P/N		L	R	dk		K		Cross recess			
		Carbon Steel	Stainless steel			max	min	max	min	Slot NO.	Insert depth		m
ST2.9	1.1	JX-Q273-ST2.9-L-ST	JX-Q273-ST2.9-L-SS	6.5, 9, 13, 16, 19	4.6	7.0	6.5	2.05	1.75	1	1.8	1.4	3
ST3.5	1.3	JX-Q273-ST3.5-L-ST	JX-Q273-ST3.5-L-SS	9.5, 13, 16, 19, 22, 25	5.4	8.0	7.5	2.35	2.05	2	1.9	1.4	3.9
ST4.2	1.4	JX-Q273-ST4.2-L-ST	JX-Q273-ST4.2-L-SS	9.5, 13, 16, 19, 22, 25, 32	6.1	10.0	9.5	2.65	2.35	2	2.4	1.9	4.4
ST4.8	1.6	JX-Q273-ST4.8-L-ST	JX-Q273-ST4.8-L-SS	9.5, 13, 16, 19, 22, 25, 32	6.9	12.0	11.5	3.15	2.85	2	2.9	2.4	4.9
ST5.5	1.8	JX-Q273-ST5.5-L-ST	JX-Q273-ST5.5-L-SS	9.5, 13, 16, 19, 22, 25, 32, 38	7.7	14.0	13.5	3.45	3.15	2	3.1	2.6	6.4
ST6.3	1.8	JX-Q273-ST6.3-L-ST	JX-Q273-ST6.3-L-SS	9.5, 13, 16, 19, 22, 25, 32, 38	9.1	14.0	13.5	3.90	3.50	3	3.6	3.1	6.9

Remark: 1. The length L can customize according to customer's need.

JX-Q274, JX-Q278 Cross recessed countersunk head tapping screws

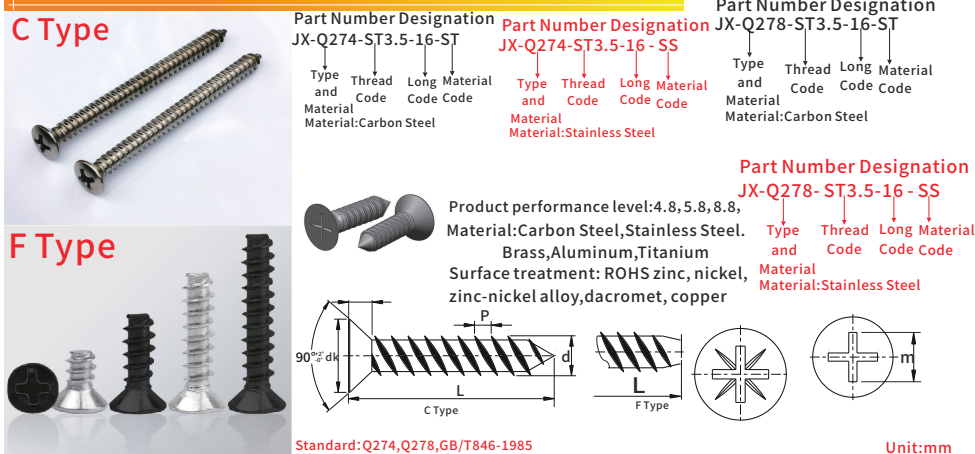

Size d	Pitch P	P/N				dk		K	Cross recess				
		C Type		F Type		Actual value	Theoretical value		max	Slot NO.	Insert depth		
ST2.9	1.1	JX-Q274-ST2.9-L-ST	JX-Q274-ST2.9-L-SS	JX-Q278-ST2.9-L-ST	JX-Q278-ST2.9-L-SS	5.5	5.2	6.3	1.7	1	2.1	1.7	3.2
ST3.5	1.3	JX-Q274-ST3.5-L-ST	JX-Q274-ST3.5-L-SS	JX-Q278-ST3.5-L-ST	JX-Q278-ST3.5-L-SS	7.3	6.9	8.2	2.35	2	2.4	1.9	4.4
ST4.2	1.4	JX-Q274-ST4.2-L-ST	JX-Q274-ST4.2-L-SS	JX-Q278-ST4.2-L-ST	JX-Q278-ST4.2-L-SS	8.4	8	9.4	2.6	2	2.6	2.1	4.6
ST4.8	1.6	JX-Q274-ST4.8-L-ST	JX-Q274-ST4.8-L-SS	JX-Q278-ST4.8-L-ST	JX-Q278-ST4.8-L-SS	9.3	8.9	10.4	2.8	2	3.2	2.7	5.2
ST5.5	1.8	JX-Q274-ST5.5-L-ST	JX-Q274-ST5.5-L-SS	JX-Q278-ST5.5-L-ST	JX-Q278-ST5.5-L-SS	10.3	9.9	11.5	3	3	3.3	2.8	6.6
ST6.3	1.8	JX-Q274-ST6.3-L-ST	JX-Q274-ST6.3-L-SS	JX-Q278-ST6.3-L-ST	JX-Q278-ST6.3-L-SS	11.3	10.9	12.6	3.15	3	3.5	3.0	6.8

Remark: 1. 长度“L”可根据客户需要定制/The length L can customize according to customer's need.

Remark: Material and surface treatment can also be manufactured according to customer requirements

AUTOMOTIVE SCREWS FASTENERS SERIES

JX-YJT/FD1088 JX-YJT 4020 Cross recessed hexagon head flange triangular tooth locking screw

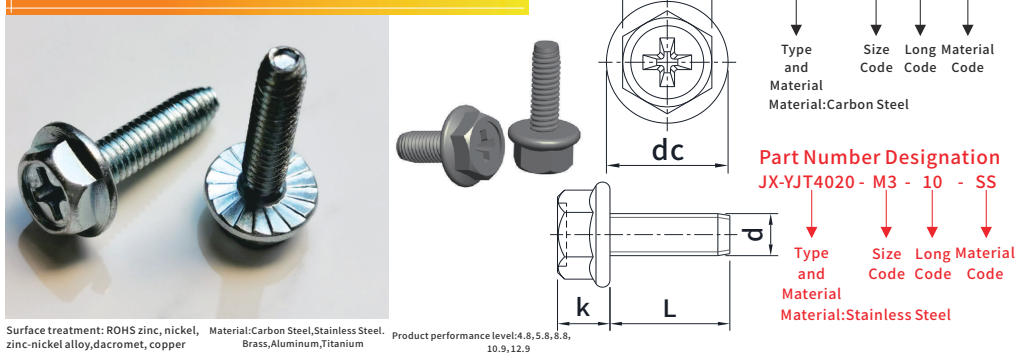

Size d	P/N		Pitch	s	k		dc	
	Carbon Steel	Stainless steel			max.	min.	max.	min.
M3	JX-YJT/FD1088-M3-10-ST	JX-YJT/FD1088-M3-10-SS	0.5	5.5	2.5	2.3	7.5	7.3
M4	JX-YJT/FD1088-M4-10-ST	JX-YJT/FD1088-M4-10-SS	0.7	7	3.5	3.3	9.5	9.3
M5	JX-YJT/FD1088-M5-10-ST	JX-YJT/FD1088-M5-10-SS	0.8	8	4.3	4.1	11.2	11
M6	JX-YJT/FD1088-M6-10-ST	JX-YJT/FD1088-M6-10-SS	1	10	5	4.8	13.2	13
M8	JX-YJT/FD1088-M8-10-ST	JX-YJT/FD1088-M8-10-SS	1.25	12	6.8	6.6	16.5	16.3

JX-Q27A Hex lobular socket pan head tapping screws



Size d	Pitch P	P/N		L	dk		K		Hexagon flower shape			
		Carbon Steel	Stainless steel		max	min	max	min	Slot NO.	t		
ST2.9	1.1	JX-Q27A-ST2.9-L-ST	JX-Q27A-ST2.9-L-SS	7 10 13 16 19	5.60	5.30	2.40	2.15	10	1.27	1.01	2.80
ST3.5	1.3	JX-Q27A-ST3.5-L-ST	JX-Q27A-ST3.5-L-SS	10 13 16 19 22 25	7.00	6.64	2.60	2.35	15	1.40	1.14	3.35
ST4.2	1.4	JX-Q27A-ST4.2-L-ST	JX-Q27A-ST4.2-L-SS	10 13 16 19 22 25 32	8.00	7.64	3.10	2.80	20	1.80	1.42	2.95
ST4.8	1.6	JX-Q27A-ST4.8-L-ST	JX-Q27A-ST4.8-L-SS	10 13 16 19 22 25 32	9.50	9.14	3.70	3.40	25	2.03	1.65	4.50
ST5.5	1.8	JX-Q27A-ST5.5-L-ST	JX-Q27A-ST5.5-L-SS	13 16 19 22 25 32 38	11.00	10.57	4.00	3.70	25	2.03	1.65	4.50
ST6.3	1.8	JX-Q27A-ST6.3-L-ST	JX-Q27A-ST6.3-L-SS	13 16 19 22 25 32 38	12.00	11.57	4.60	4.30	30	2.42	2.02	5.60

Remark: 1. The length L can customize according to customer's need.

Remark: Material and surface treatment can also be manufactured according to customer requirements

http://www.juxinfasteners.com

http://www.juxinfasteners.com