

JX Threaded Inserts for Plastic Series

Threaded Inserts Nuts

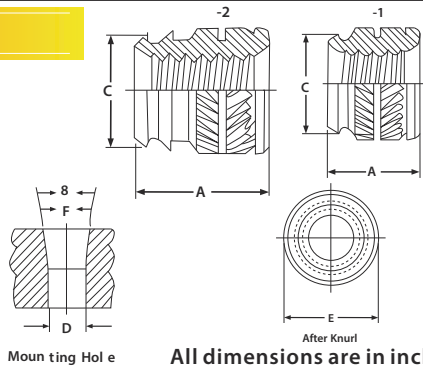

Moun ting Hol e All dimensions are in inches

Thread Size	TYPE		Thread Code	Length Code	A + .005	E + .005	C + .005	Hole Size in Material		
	Brass	Stainless Steel						Min.Hole Depth	D + .002	F + .002
.060-80 (#0-80)	JX-IUB	JX-IUC	080 ^{NS(2)}	1	.115	.141	.123	.155	.118	.123
					2	.188	.115	.228	.107	.123
.086-56 (#2-56)	JX-IUB	JX-IUC	256 ⁽²⁾	1	.115	.141	.123	.155	.118	.123
					2	.188	.115	.228	.107	.123
.112-40 (#4-40)	JX-IUB	JX-IUC	440	1	.135	.172	.157	.175	.153	.159
					2	.219	.149	.259	.141	.159
.138-32 (#6-32)	JX-IUB	JX-IUC	632	1	.150	.219	.203	.190	.199	.206
					2	.250	.190	.290	.185	.206
.164-32 (#8-32)	JX-IUB	JX-IUC	832	1	.185	.250	.230	.255	.226	.234
					2	.312	.213	.352	.208	.234
.190-24 (#10-24)	JX-IUB	JX-IUC	024 ^{NS}	1	.225	.297	.272	.265	.267	.277
					2	.375	.251	.415	.246	.277
.190-32 (#10-32)	JX-IUB	JX-IUC	032	1	.225	.297	.272	.265	.267	.277
					2	.375	.251	.415	.246	.277
.250-20 (1/4-20)	JX-IUB	JX-IUC ^{NS}	0420	1	.300	.375	.354	.340	.349	.363
					2	.500	.332	.540	.321	.363
.250-28 (1/4-28)	JX-IUB	JX-IUC	0428 ^{NS}	1	.300	.375	.354	.340	.349	.363
					2	.500	.332	.540	.321	.363
.313-18 (5/16-18)	JX-IUB	JX-IUC	0518 ^{NS}	1	.335	.469	.439	.375	.431	.448
					2	.562	.406	.602	.401	.448
.375-16 (3/8-16)	JX-IUB	JX-IUC	0616 ^{NS}	1	.375	.563	.532	.415	.523	.540
					2	.625	.493	.665	.488	.540

All dimensions are in millimeters

Thread Size	TYPE		Thread Code	Length Code	A +0.13	E + .005	C +0.13	Hole Size in Material		
	Brass	Stainless Steel						Min.Hole Depth	D + .005	F + .005
M2.5x0.45	JX-IUB	JX-IUC	M2.5	1	3.43	4.37	3.99	4.44	3.80	4.04
					2	5.56	3.79	6.58	3.58	4.04
M3x0.5	JX-IUB	JX-IUC	M3	1	3.43	4.37	3.99	4.44	3.89	4.04
					2	5.56	3.79	6.58	3.58	4.04
M3x0.5	JX-IUBB	JX-IUC	M3	1	3.81	5.56	5.16	4.83	5.05	5.23
					2	6.35	4.83	7.42	4.7	5.23
M3.5x0.6	JX-IUB	JX-IUC	M3.5	1	3.81	5.56	5.16	4.83	5.05	5.23
					2	6.35	4.83	7.42	4.7	5.23
M4x0.7	JX-IUB	JX-IUC	M4	1	4.7	6.35	5.84	5.72	5.74	5.94
					2	7.92	5.41	8.94	5.28	5.94
M5x0.8	JX-IUB	JX-IUC	M5	1	5.72	7.54	6.91	6.74	6.78	7.03
					2	9.53	6.38	10.55	6.25	7.03
M5x0.8	JX-IUBB	JX-IUCC	M5	1	6.71	8.33	7.83	7.72	7.7	8.0
					2	11.1	7.16	12.12	7.06	8.0
M6x1.0	JX-IUB	JX-IUC	M6	1	7.62	9.52	8.99	8.64	8.86	9.22
					2	12.7	8.43	13.72	8.15	9.22
M8x1.25	JX-IUB	JX-IUC	M8	1	8.51	11.91	11.15	9.53	10.95	11.38
					2	14.27	10.31	15.29	10.19	11.38

Remark:The material and treatment surface can also be manufactured according to customer requirements

http://www.juxinfasteners.com

JX Threaded Inserts for Plastic Series

Threaded Inserts Nuts



英制牙型 Thread Size	ABS		Polycarbonate 聚碳酸酯		英制牙型 Thread Size	ABS		Polycarbonate 聚碳酸酯	
	Pull out 拔出力(lbs.)	Torque out (in.lbs.)	Pull out 拔出力(lbs.)	Torque out (in.lbs.)		Pull out 拔出力(lbs.)	Torque out (in.lbs.)	Pull out 拔出力(lbs.)	Torque out (in.lbs.)
M2.5x0.45	730	1.58	1080	1.81	.112-40 (#4-40)	165	14	245	16
						.138-32 (#6-32)	268	25	295
M3x0.5	730	1.58	1080	1.81	.164-32 (#8-32)	328	36	385	52
						.190-24 (#10-24)	385	54	565
M3.5x0.6	1450	4.07	1710	5.88	.190-32 (#10-32)	385	54	565	80
						.250-20 (1/4-20)	480	135	600
M4x0.7	1450	4.07	1710	5.88	.250-28 (1/4-28)	480	135	600	190
M5x0.8	1710	6.1	2510	9.04					
M6x1.0	2130	15.26	2660	21.47					

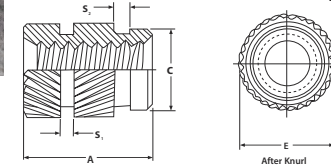

Material:Steel, stainless steel ,Brass

All dimensions are in inches

Thread Size	TYPE		Thread Code	A + .005	E + .005	C + .005	S1 Nom.	S2 Nom.	Hole Size in Material	
	Brass	Stainless Steel							Min.Hole Depth	Hole Dia + .003 - .00
.086-56 (#2-56)	JX-IUTB	JX-IUTC	256	.157	.147	.121	.031	.031	.187	.127
.112-40 (#4-40)	JX-IUTB	JX-IUTC	440	.226	.179	.152	.031	.031	.256	.158
.138-32 (#6-32)	JX-IUTB	JX-IUTC	632	.281	.210	.183	.031	.031	.311	.189
.164-32 (#8-32)	JX-IUTB	JX-IUTC	832	.321	.243	.217	.031	.040	.351	.223
.190-24 (#10-24)	JX-IUTB	JX-IUTC	024 ^{NS}	.375	.273	.247	.046	.046	.405	.253
.190-32 (#10-32)	JX-IUTB	JX-IUTC	032	.375	.273	.247	.046	.046	.405	.253
.250-20 (1/4-20)	JX-IUTB	JX-IUTC	0420	.500	.342	.310	.046	.062	.530	.316
.250-28 (1/4-28)	JX-IUTB	JX-IUTC	0428 ^{NS}	.500	.342	.310	.046	.062	.530	.316
.375-16 (3/8-16)	JX-IUTB	JX-IUTC	0616 ^{NS}	.500	.509	.462	.046	.062	.530	.466

All dimensions are in millimeters

Thread Size	TYPE		Thread Code	A +0.13	E +0.23	C +0.13	S1 Nom.	S2 Nom.	Hole Size in Material	
	Brass	Stainless Steel							Min.Hole Depth	Hole Dia. +0.08
M2x0.4	JX-IUTB	JX-IUTC	M2	4.0	3.73	3.07	0.79	0.79	4.75	3.23
M2.5x0.45	JX-IUTB	JX-IUTC	M2.5	5.74	4.55	3.86	0.79	0.79	6.5	4.01
M3x0.5	JX-IUTB	JX-IUTC	M3	5.74	4.55	3.86	0.79	0.79	6.5	4.01
M3.5x0.6	JX-IUTB	JX-IUTC	M3.5	7.14	5.33	4.65	0.79	0.79	7.9	4.81
M4x0.7	JX-IUTB	JX-IUTC	M4	8.15	6.17	5.51	0.79	1.02	8.91	5.67
M5x0.8	JX-IUTB	JX-IUTC	M5	9.52	6.93	6.27	1.17	1.17	10.28	6.43
M6x1.0	JX-IUTB	JX-IUTC	M6	12.7	8.69	7.87	1.17	1.58	13.46	8.03

Remark:The material and treatment surface can also be manufactured according to customer requirements

http://www.juxinfasteners.com