

Fasteners for Metal Sheets and Panels Series

JX-PF11, JX-PF12 Self-Clinching Panel Fastener Assemblies

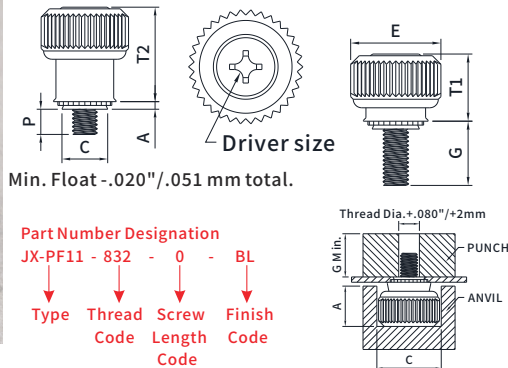

Color: Material Natural color and Black

All dimensions are in inches.

Thread Size	Type		Thread Code	Screw Length Code	A (Shank) Max.	Min. Sheet Thickness	Hole Size In Sheet $+0.03$ $-.000$	C Max.	E ± 0.10	G ± 0.25	P ± 0.25	T1 Nom.	T2 Nom.	Driver Size	Min. Dist. Hole C/L To Edge
	Knurled Cap	Smooth Cap													
.112-40 (#4-40)	JX-PF11	JX-PF12	440	0	.036	.036	.219	.218	.417	.170	.000	.310	.450	#1	.280
				1						.230	.060				
				2						.290	.120				
.138-32 (#6-32)	JX-PF11	JX-PF12	632	0	.036	.250	.249	.450	.230	.000	.450	.640	#2	.290	
				1					.290	.060					
				2					.350	.120					
.164-32 (#8-32)	JX-PF11	JX-PF12	832	0	.036	.312	.311	.514	.230	.000	.450	.640	#2	.330	
				1					.290	.060					
				2					.350	.120					
.190-32 (#10-32)	JX-PF11	JX-PF12	032	0	.036	.312	.311	.514	.230	.000	.450	.640	#2	.330	
				1					.290	.060					
				2					.350	.120					
.250-20 (1/4-20)	JX-PF11	JX-PF12	0420	0	.036	.375	.374	.575	.350	.060	.530	.790	#3	.460	
				1					.290	.000					
				2					.410	.120					

All dimensions are in millimeters.

Thread Size	Type		Thread Code	Screw Length Code	A (Shank) Max.	Min. Sheet Thickness	Hole Size In Sheet $+0.08$	C Max.	E ± 0.25	G ± 0.64	P ± 0.64	T1 Nom.	T2 Nom.	Driver Size	Min. Dist. Hole C/L To Edge
	Knurled Cap	Smooth Cap													
M3x0.5	JX-PF11	JX-PF12	M3	0	0.92	5.56	5.54	10.59	4.32	0	7.87	11.43	#1	7.11	
				1					5.84	1.52					
				2					7.37	3.05					
M3.5x0.6	JX-PF11	JX-PF12	M3.5	0	0.92	6.35	6.33	11.43	5.84	0	11.43	16.26	#2	7.37	
				1					7.37	1.52					
				2					8.89	3.05					
M4x0.7	JX-PF11	JX-PF12	M4	0	0.92	7.92	7.9	13.06	7.37	1.52	11.43	16.26	#2	8.38	
				1					8.89	3.05					
				2					10.41	4.57					
M5x0.8	JX-PF11	JX-PF12	M5	0	0.92	7.92	7.9	13.06	7.37	1.52	11.43	16.26	#2	8.38	
				1					8.89	3.05					
				2					10.41	4.57					
M6x1	JX-PF11	JX-PF12	M6	0	0.92	9.53	9.5	14.61	8.89	1.52	13.46	20.07	#3	11.68	
				1					10.41	3.05					
				2					12.00	6.10					

Remark: We only show part of the specifications, we can also produce various sizes according to the customer's requirements

Fasteners for Metal Sheets and Panels Series

JX-PF13, JX-PF14 Large Knob, Spring-Loaded Panel Fastener Assemblies

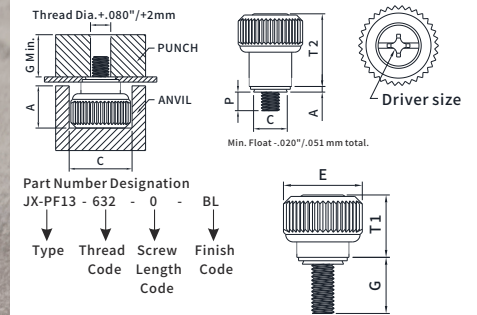

Color: Natural Color and Black

1. Material: Aluminum+Stainless Steel+steel
 2. Material: Aluminum+Stainless+Stainless

All dimensions are in inches.

Thread Size	Type		Thread Code	Screw Length Code	A (Shank) Max.	Min. Sheet Thickness	Hole Size In Sheet $+0.03$ $-.000$	C Max.	E ± 0.10	G ± 0.25	P ± 0.25	T1 Nom.	T2 Nom.	Driver Size	Min. Dist. Hole C/L To Edge
	Knurled Cap	Smooth Cap													
.112-40 (#4-40)	JX-PF13	JX-PF14	440	0	.036	.219	.218	.417	.170	.000	.310	.450	#1	.280	
				1					.230	.060					
				2					.290	.120					
.138-32 (#6-32)	JX-PF13	JX-PF14	632	0	.036	.250	.249	.450	.230	.000	.450	.640	#2	.290	
				1					.290	.060					
				2					.350	.120					
.164-32 (#8-32)	JX-PF13	JX-PF14	832	0	.036	.312	.311	.514	.230	.000	.450	.640	#2	.330	
				1					.290	.060					
				2					.350	.120					
.190-32 (#10-32)	JX-PF13	JX-PF14	032	0	.036	.312	.311	.514	.230	.000	.450	.640	#2	.330	
				1					.290	.060					
				2					.350	.120					
.250-20 (1/4-20)	JX-PF13	JX-PF14	0420	0	.036	.375	.374	.575	.350	.060	.530	.790	#3	.460	
				1					.290	.000					
				2					.410	.120					

All dimensions are in millimeters.

Thread Size	Type		Thread Code	Screw Length Code	A (Shank) Max.	Min. Sheet Thickness	Hole Size In Sheet $+0.08$	C Max.	E ± 0.25	G ± 0.64	P ± 0.64	T1 Nom.	T2 Nom.	Driver Size	Min. Dist. Hole C/L To Edge
	Knurled Cap	Smooth Cap													
M3x0.5	JX-PF13	JX-PF14	M3	0	0.92	5.56	5.54	10.59	4.32	0	7.87	11.43	#1	7.11	
				1					5.84	1.52					
				2					7.37	3.05					
M3.5x0.6	JX-PF13	JX-PF14	M3.5	0	0.92	6.35	6.33	11.43	5.84	0	11.43	16.26	#2	7.37	
				1					7.37	1.52					
				2					8.89	3.05					
M4x0.7	JX-PF13	JX-PF14	M4	0	0.92	7.92	7.9	13.06	7.37	1.52	11.43	16.26	#2	8.38	
				1					8.89	3.05					
				2					10.41	4.57					
M5x0.8	JX-PF13	JX-PF14	M5	0	0.92	7.92	7.9	13.06	7.37	1.52	11.43	16.26	#2	8.38	
				1					8.89	3.05					
				2					10.41	4.57					
M6x1	JX-PF13	JX-PF14	M6	0	0.92	9.53	9.5	14.61	8.89	1.52	13.46	20.07	#3	11.68	
				1					10.41	3.05					
				2					12.00	6.10					

Remark: We only show part of the specifications, we can also produce various sizes according to the customer's requirements