

JX Fasteners for Metal Sheets and Panels Series

STUDS (HEXAGON HEAD)

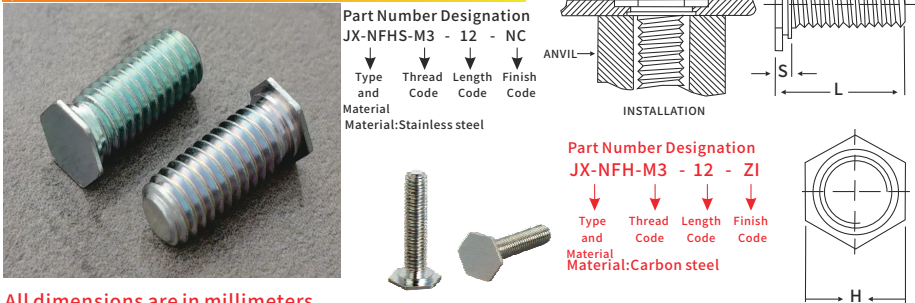

All dimensions are in millimeters

METRIC	Thread Size X Pitch	Type		Thread Code	Length "L"+0.4 Length Code in mm	Min. Sheet Thickness	Hole Size in Sheet +0.08	H ±0.4	S Max.
		Carbon Steel	Stainless Steel						
	M3x0.5	JX-NFH	JX-NFHS	M3	4 6 10 12 14 15 16 18 20	1	4.8	6	1.25
	M4x0.7	JX-NFH	JX-NFHS	M4	10 12 14 15 18 20 22 25	1	4.8	6	1.25
	M5x0.8	JX-NFH	JX-NFHS	M5	12 15 18 20 25	1	5.0	6.35	1.25
	M6x1	JX-NFH	JX-NFHS	M6	12 15 18 20 25	1.3	6.0	7	1.4

SCREWLOCK STANDOFFS



All dimensions are in inches

UNIFIED	Thread Size	Type		Thread Code	Length Code	L +0.002 -0.005	Min. Sheet Thickness	Hole Size in Sheet +.003	C -.005	E Nom.
		Carbon Steel	Stainless Steel							
	.112-40 (#4-40)	JX-DSO	JX-DSOS	440	.250 .270	.250 .270	.037-.250	.166	.165	.194

All dimensions are in millimeters

METRIC	Thread Size X Pitch	Type		Thread Code	Length Code	L +0.05 -0.13	Min. Sheet Thickness	Hole Size in Sheet +0.08	C -0.13	E Nom.
		Carbon Steel	Stainless Steel							
	M3x0.5	JX-DSO	JX-DSOS	M3	6.35 7	6.35 7	0.94-6.35	4.2	4.19	4.92

Remark: We only show part of the specifications, we can also produce various sizes according to the customer's requirements

JX Fasteners for Metal Sheets and Panels Series

BLIND NUTS



UNIFIED	Thread Size	Type		Thread Code	Shank Code	A Max.	Min. Sheet Thickness	Hole Size in Sheet +.003 -.000	Barrel Diameter B Max.	Shank Diameter C Max.	E ±.006	Max. Depth Full Threads H	L Max.	T ±.010
		Carbon Steel	Stainless Steel											
	.112-40 (#4-40)	JX-B	JX-BS	440	1	.038	.040	.166	.149	.165	.250	.21	.335	.38
	.138-32 (#6-32)	JX-B	JX-BS	632	1	.038	.040	.1875	.169	.187	.275	.23	.335	.38
	.164-32 (#8-32)	JX-B	JX-BS	832	1	.038	.040	.213	.204	.212	.315	.28	.385	.44
	.190-20 (#10-32)	JX-B	JX-BS	032	1	.038	.040	.250	.235	.249	.335	.27	.385	.44
	.250-20 (#1/4-20)	JX-B	JX-BS	0420	1	.054	.056	.344	.305	.343	.433	.31	.500	.56

All dimensions are in millimeters

METRIC	Thread Size x Pitch	Type		Thread Code	Shank Code	A Max.	Min. Sheet Thickness	Hole Size in Sheet +0.08 -0.00	Barrel Diameter B Max.	Shank Diameter C Max.	E ±0.15	Min. Depth Full Threads H	L Max.	T ±0.25
		Carbon Steel	Stainless Steel											
	M3x0.5	JX-B	JX-BS	M3	1	0.97	1	4.25	3.8	4.22	6.35	5.3	8.5	9.6
	M4x0.7	JX-B	JX-BS	M4	1	0.97	1	5.4	5.2	5.38	8	7.1	9.8	11.2
	M5x0.8	JX-B	JX-BS	M5	1	0.97	1	6.4	6	6.38	9	6.8	9.8	11.2
	M6x1	JX-B	JX-BS	M6	1	1.37	1.4	8.75	7.8	8.72	11	7.8	12.7	14.3

Remark: We only show part of the specifications, we can also produce various sizes according to the customer's requirements