

BLIND RIVET NUTS FASTENERS SERIES

Special Blind Rivet Nuts

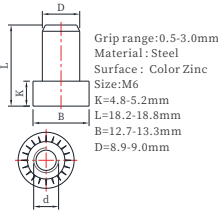

JX-F5-M6-18.8



Material: Steel
Surface: Zinc
Color Zinc
Size: M6
Grip range: 0.5-3.0mm
K=4.8-5.2mm
L=18.2-18.8mm
B=12.7-13.3mm
D=8.9-9.0mm



JX-F-M6-HEX(F)-B20-20

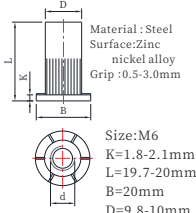

Material: Steel
Surface: Zinc
nickel alloy
Grip: 0.5-3.0mm

Size: M6
K=1.8-2.1mm
L=19.7-20mm
B=20mm
D=9.8-10mm



JX-F2.5-M6-HEX(F)-B18-19
A: JX-F-M6-HEX(F)-B18-1-18
B: JX-F-M6-HEX(F)-B18-1.5-16

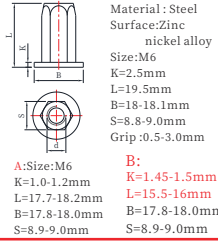

Material: Steel
Surface: Zinc
nickel alloy
Size: M6
K=2.5mm
L=19.5mm
B=18-18.1mm
S=8.8-9.0mm
Grip: 0.5-3.0mm

A: Size: M6
K=1.0-1.2mm
L=17.7-18.2mm
B=17.8-18.0mm
S=8.9-9.0mm



JX-F-M6-HEX(F)-B18-19

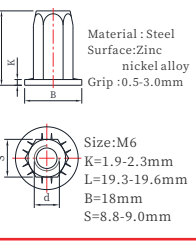

Material: Steel
Surface: Zinc
nickel alloy
Grip: 0.5-3.0mm

Size: M6
K=1.9-2.3mm
L=19.3-19.6mm
B=18mm
S=8.8-9.0mm



JX-F-M6-R-SQU-B17-20

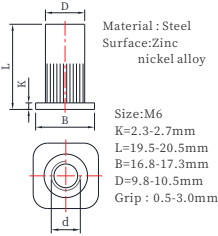

Material: Steel
Surface: Zinc
nickel alloy
Size: M6
K=2.3-2.7mm
L=19.5-20.5mm
B=16.8-17.3mm
D=9.8-10.5mm
Grip: 0.5-3.0mm



JX-F-M6-R-B20-20

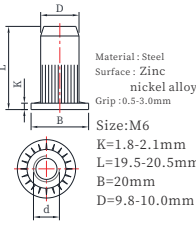

Material: Steel
Surface: Zinc
nickel alloy
Grip: 0.5-3.0mm

Size: M6
K=1.8-2.1mm
L=19.5-20.5mm
B=20mm
D=9.8-10.0mm



JX-F3-M6-R-B18-17-ST

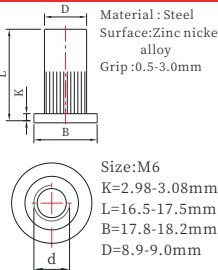

Material: Steel
Surface: Zinc
nickel alloy
Grip: 0.5-3.0mm

Size: M6
K=2.98-3.08mm
L=16.5-17.5mm
B=17.8-18.2mm
D=8.9-9.0mm



JX-S-M6-R-B12-20

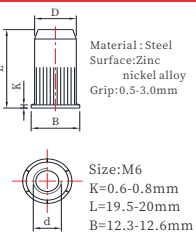

Material: Steel
Surface: Zinc
nickel alloy
Grip: 0.5-3.0mm

Size: M6
K=0.6-0.8mm
L=19.5-20mm
B=12.3-12.6mm
D=9.8-10.0mm



JX-F-M6-R-B18-19

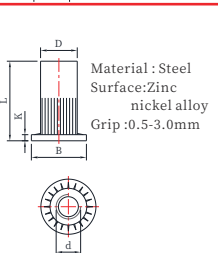

Material: Steel
Surface: Zinc
nickel alloy
Grip: 0.5-3.0mm



JX-BF2.5-M6-RX9-19-SS

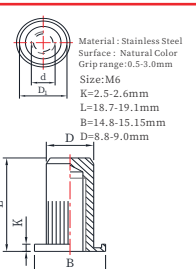

Material: Stainless Steel
Surface: Natural Color
Grip range: 0.5-3.0mm
Size: M6
K=2.5-2.6mm
L=18.7-19.1mm
B=14.8-15.15mm
D=8.8-9.0mm

BLIND RIVET NUTS FASTENERS SERIES

Flat Head Closed End Hexagonal Body With Seal Blind rivet nuts

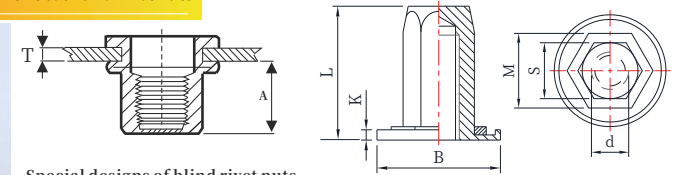

Special designs of blind rivet nuts
Material: Steel
Sealing nut with molded-on captive plastic seal.
Used on car boot hinges to provide a pressure-tight connection.

Unit:mm

规格Size	P/N 料号	T	L _{±0.3}	A	D	B _{±0.5}	k _{±0.1}
M5	JX-BF-M5-HEX(F)-WS-18	0.5-3.0	18	13.5	7.0	12.5	1.5
M6	JX-BF-M6-HEX(F)-WS-24.5	0.5-3.0	24.5	18.5	9.0	18.0	2.5
M8	JX-BF-M8-HEX(F)-WS-28.7	0.5-3.0	28.7	21.7	11.0	21.0	2.4

Blind Rivet studs

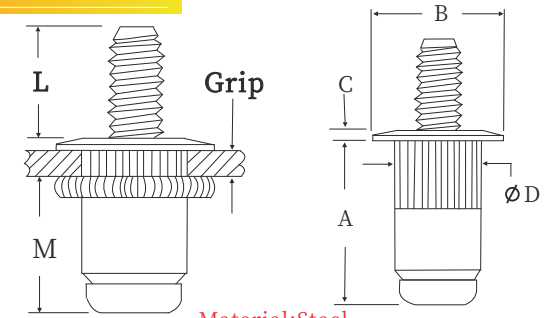

Material: Steel

Unit:mm

All dimensions are in millimeters

Thread Size	Grip Code	Grip Range	Stud Length "L" Nom. (at Max. Grip)			A ±0.01	B ±0.03	C Nom.	ØD Max.	M Ref.	Hole Size In Sheet +0.015
			12	15	20						
M4 x 0.7	2.0	0.5 - 2.0	JX-F-M4-R-BD-12	JX-F-M4-R-BD-15	JX-F-M4-R-BD-20	12.45	9.91	0.76	6.73	9.53	6.75
			10.7	13.7	18.7						
M4 x 0.7	3.3	2.0 - 3.3	JX-F-M4-R-BD-10.7	JX-F-M4-R-BD-13.7	JX-F-M4-R-BD-18.7	13.72	9.91	0.76	6.73	9.53	6.75
			12	15	20						
M5 x 0.8	3.3	0.5 - 3.3	JX-F-M5-R-BD-12	JX-F-M5-R-BD-15	JX-F-M5-R-BD-20	13.85	10.54	0.76	7.52	9.78	7.6
			9.6	12.6	17.6						
M5 x 0.8	5.7	3.3 - 5.7	JX-F-M5-R-BD-9.6	JX-F-M5-R-BD-12.6	JX-F-M5-R-BD-17.6	16.64	10.54	0.76	7.52	9.78	7.6
			15	20	25						
M6 x 1	4.2	0.7 - 4.2	JX-F-M6-R-BD-15	JX-F-M6-R-BD-20	JX-F-M6-R-BD-25	17.02	12.7	0.76	9.91	11.94	10
			12.6	17.6	22.6						
M6 x 1	6.6	4.2 - 6.6	JX-F-M6-R-BD-12.6	JX-F-M6-R-BD-17.6	JX-F-M6-R-BD-22.6	19.56	12.7	0.76	9.91	11.94	10
			16	22	28						
M8 x 1.25	3.8	0.7 - 3.8	JX-F-M8-R-BD-16	JX-F-M8-R-BD-22	JX-F-M8-R-BD-28	20.45	17.4	0.89	13.46	14.86	13.5
			13	17.9	23.9						
M8 x 1.25	7.9	3.8 - 7.9	JX-F-M8-R-BD-13	JX-F-M8-R-BD-17.9	JX-F-M8-R-BD-23.9	23.37	17.4	0.89	13.46	13.72	13.5
			20	25	30						
M10 x 1.5	3.8	0.7 - 3.8	JX-F-M10-R-BD-20	JX-F-M10-R-BD-25	JX-F-M10-R-BD-30	20.45	17.4	0.89	13.46	14.86	13.5
			17	20.9	25.9						
M10 x 1.5	7.9	3.8 - 7.9	JX-F-M10-R-BD-17	JX-F-M10-R-BD-20.9	JX-F-M10-R-BD-25.9	23.37	17.4	0.89	13.46	13.72	13.5
			20	25	30						

Surface treatment can also be manufactured according to customer requirements