

BLIND RIVET NUTS FASTENERS SERIES

Steel Flat Head Open end Square Blind rivet Nuts

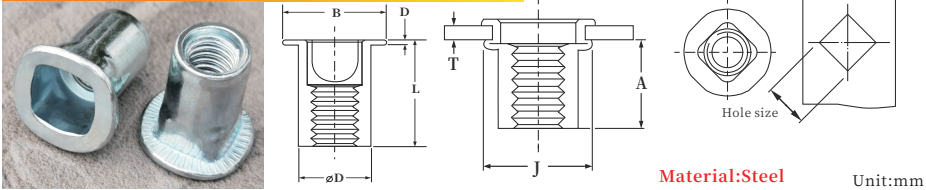

Material:Steel Unit:mm

Size	P/N	Grip Range e	A Rer	Hole Size +0.1	D +0.07 -0.1	J	B ±0.2	K ±0.2	L +0.3
M5	JX-F-M5-11.4-SQU	0.5-1.5	8.0	7.0	6.9	10.4	10.5	0.60	11.2
	JX-F-M5-13-SQU	1.5-3.0	8.0	7.0	6.9	10.4	10.5	0.60	12.7
M6	JX-F-M6-15.5-SQU	0.5-2.5	8.5	9.0	8.9	13.5	13.5	0.80	15.5
	JX-F-M6-17.5-SQU	2.5-4.0	9.5	9.0	8.9	13.5	13.5	0.80	17.2
M8	JX-F-M10-18.9-SQU	1.0-3.0	11.5	11.3	10.9	16.4	15.2	1.5	18.9

Flat Head Open End Peel Blind Rivet nuts



Material:Steel, Stainless Steel

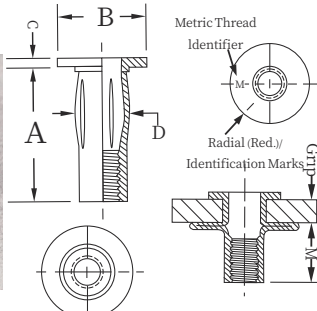

All dimensions are in inches

Unit:Inchs

SIZE	Grip Range	P/N		A +0.38	ΦB Nom	C Nom	ΦD Max.	M Ref.	Hole Size In Sheet +0.15
		Steel	Stainless steel						
#10-32	.020-.175	JX-FR1032-781-ST	JX-FR1032-781-SS	.781	.500	.038	.272	.425	.273
#10-32	.175-.320	JX-FR1032-921-ST	JX-FR1032-921-SS	.921	.500	.038	.272	.425	.273
1/4-20	.020-.280	JX-FR0420-1-ST	JX-FR0420-1-SS	1.000	.625	.058	.346	.505	.347
1/4-20	.280-.500	JX-FR0420-1234-ST	JX-FR0420-1234-SS	1.234	.625	.058	.346	.505	.347
5/16-18	.020-.280	JX-FR0518-1141-ST	JX-FR0518-1141-SS	1.141	.750	.062	.437	.570	.438
5/16-18	.280-.500	JX-FR0518-1375-ST	JX-FR0518-1375-SS	1.375	.750	.062	.437	.570	.438
3/8-16	.020-.280	JX-0616-1218-ST	JX-0616-1218-SS	1.218	.875	.088	.514	.605	.515
3/8-16	.280-.500	JX-0616-1437-ST	JX-0616-1437-SS	1.437	.875	.088	.514	.605	.515

Flat Head Open End Peel Blind Rivet nuts



SIZE	Grip Range	P/N		A +0.38	ΦB Nom	C Nom	ΦD Max.	M Ref.	Hole Size In Sheet +0.15
		Steel	Stainless steel						
M6x1.0	0.50-7.1	JX-FR-M6-25.4-ST	JX-FR-M6-25.4-SS	25.40	15.87	1.5	8.79	12.8	8.8
M6x1.0	7.1-12.7	JX-FR-M6-31.32-ST	JX-FR-M6-31.32-SS	31.32	15.87	1.5	8.79	12.8	8.8
M8x1.25	0.50-7.1	JX-FR-M8-28.95-ST	JX-FR-M8-28.95-SS	28.95	19.04	1.57	11.1	14.47	11.1
M8x1.25	7.1-12.7	JX-FR-M8-34.9-ST	JX-FR-M8-34.9-SS	34.90	19.04	1.57	11.1	14.47	11.11
M10x1.5	0.50-7.1	JX-FR-M10-30.94-ST	JX-FR-M10-30.94-SS	30.94	22.23	2.24	13.06	15.75	13.07

Remark:Surface treatment can also be manufactured according to customer requirements

BLIND RIVET NUTS FASTENERS SERIES

High Flat Head Close End Half Hexagon Blind rivet Nuts

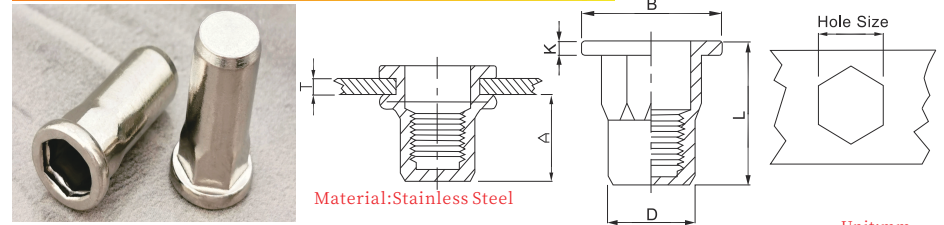

Material:Stainless Steel

Unit:mm

SIZE	P/N		Grip Range T	A	Hole Size +0.1 -0	D -0.03 -0.2	B±0.35	K	L±0.3
	Stainless Steel								
M5	JX-BF2.5-M5-HEX(H)-20-SS		0.5-2.5	15-17	7.0	7.0	10	2.3-2.7	20.0
M6	JX-BSF2.5-M6-HEX(H)-23.5-SS		2.0-4.0	17.5-19.5	9.0	9.0	13	2.4-2.6	23.0

High Flat Head Open end Half Hexagon Blind Rivet Nuts

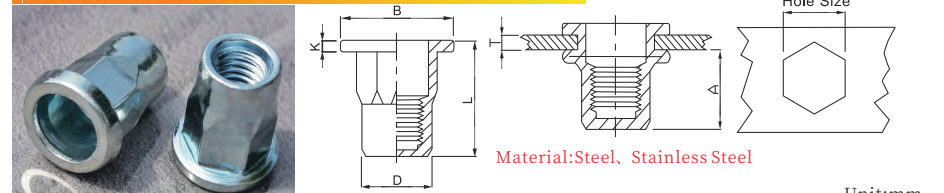

Material:Steel, Stainless Steel

Unit:mm

SIZE	P/N		Grip Range T	A	Hole Size +0.1 0	D	B	K ±0.2	L Steel	L ---
	Steel	Stainless Steel								
M5	JX-F2.5-M5-HEX(H)-ST	JX-F2.5-M5-HEX(H)-SS	0.5-2.5	10.0-14.75	7.0	6.95-7.07	9.0-9.2	2.5	15	15
M6	JX-F2.5-M6-HEX(H)-15-ST	JX-F2.5-M6-HEX(H)-SS-19	0.5-2.5	10.0-14.75	9.0	8.8-8.97	11.8-12.2	2.5	15	19
M6	JX-F2-M6-HEX(H)-14-D18-ST		0.5-1.5	10.0-13.75	9.0	8.8-8.95	17.5-18.5	2.0	14	

High Flat Head Open end Knurl Blind Rivet Nuts

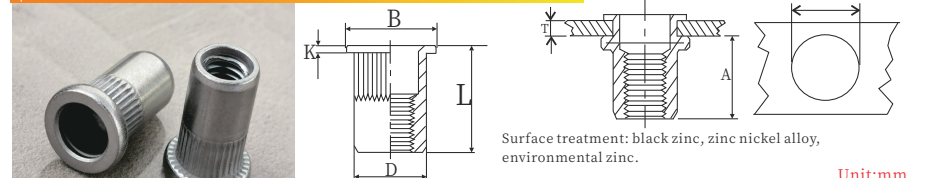

Surface treatment: black zinc, zinc nickel alloy, environmental zinc.

Unit:mm

SIZE	P/N	Grip Range T	A	Hole Size +0.1 -0	D	B	K ±0.1	L ±0.3

Material:Carbon Steel

High Flat Head Colsed end Knurl Blind Rivet Nuts

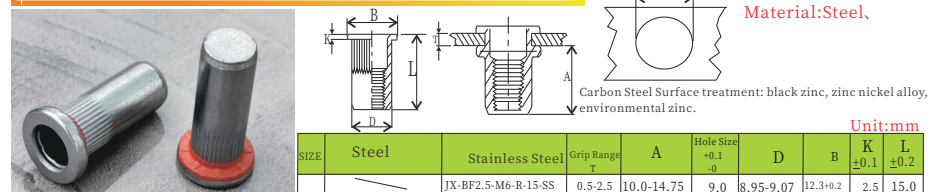

Material:Steel,

Carbon Steel Surface treatment: black zinc, zinc nickel alloy, environmental zinc.

Unit:mm

SIZE	Steel	Stainless Steel	Grip Range T	A	Hole Size +0.1 -0	D	B	K ±0.1	L ±0.2

Remark:Surface treatment can also be manufactured according to customer requirements