

BLIND RIVET NUTS FASTENERS SERIES

Flat Head Open Knurled Body Blind rivet nuts

Surface treatment: color zinc, ROHS blue zinc, zinc nickel alloy, can also be produced according to customer requirements

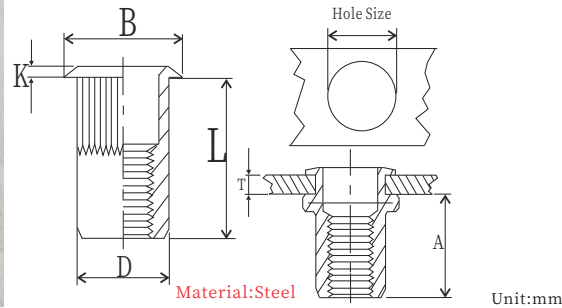

| Thread Size | Part No | Grip Range T | Hole Size $\begin{smallmatrix} +.006 \\ -.000 \end{smallmatrix}$ | B $\begin{smallmatrix} \pm .010 \\ \pm .205 \end{smallmatrix}$ | K $\pm .003$ | L $+ .015$ | D Max | A Max |
|-------------|--------------------|--------------|---------------------------------------------------------------------|-------------------------------------------------------------------|-----------------|---------------|----------|----------|
| #6-32UNC | JX-F-632-R-BS420 | .020-.080 | 17/64(.2656) | .390 | .030 | .420 | .265 | .305 |
| #6-32UNC | JX-F-632-R-BS470 | .080-.130 | 17/64(.2656) | .390 | .030 | .470 | .265 | .305 |
| #8-32UNC | JX-F-832-R-BS420 | .020-.080 | 17/64(.2656) | .390 | .030 | .420 | .265 | .305 |
| #8-32UNC | JX-F-832-R-BS470 | .080-.130 | 17/64(.2656) | .390 | .030 | .470 | .265 | .305 |
| #10-24UNC | JX-F-024-R-BS475 | .020-.130 | 19/64(.2969) | .415 | .030 | .475 | .296 | .315 |
| #10-24UNC | JX-F-024-R-BS585 | .130-.225 | 19/64(.2969) | .415 | .030 | 0.585 | .296 | .315 |
| #10-32UNC | JX-F-032-R-BS475 | .020-.130 | 19/64(.2969) | .415 | .030 | .475 | .296 | .315 |
| #10-32UNC | JX-F-032-R-BS585 | .130-.225 | 19/64(.2969) | .415 | .030 | .585 | .296 | .315 |
| 1/4-20UNC | JX-F-0420-R-BS580 | .027-.165 | 25/64(.3906) | .500 | .030 | .580 | .390 | .380 |
| 1/4-20UNC | JX-F-0420-R-BS680 | .165-.260 | 25/64(.3906) | .500 | .035 | .680 | .390 | .380 |
| 5/16-18UNC | JX-F-0518-R-BS680 | .027-.150 | 17/32(.5312) | .685 | .035 | .690 | .530 | .470 |
| 5/16-18UNC | JX-F-0518-R-BS690 | .150-.312 | 17/32(.5312) | .685 | .035 | .805 | .530 | .425 |
| 3/8-16UNC | JX-F-0616-R-BS690 | .027-.150 | 17/32(.5312) | .685 | .035 | .690 | .530 | .470 |
| 3/8-16UNC | JX-F-0616-R-BS805 | .150-.312 | 17/32(.5312) | .685 | .047 | .805 | .530 | .425 |
| 1/2-13UNC | JX-F-0813-R-BS1150 | .063-.200 | 11/16(.6875) | .865 | .047 | 1.150 | .685 | .850 |
| 1/2-13UNC | JX-F-0813-R-BS1300 | .200-.350 | 11/16(.6875) | .865 | .047 | 1.30 | .685 | .850 |
| 1/2-13UNC | JX-F-0813-R-BS1450 | .365-.500 | 11/16(.6875) | .865 | .047 | 1.45 | .685 | .860 |

Material:Steel

Unit:mm

| Thread Size | Part No | Grip Range T | Hole Size $\begin{smallmatrix} +.15 \\ -.000 \end{smallmatrix}$ | B $\begin{smallmatrix} \pm 0.25 \\ \pm 0.67 \end{smallmatrix}$ | K $\pm .008$ | L $+0.38$ | D Max | A Max |
|-------------|-----------------------|--------------|--------------------------------------------------------------------|-------------------------------------------------------------------|-----------------|--------------|----------|----------|
| M4X0.7 | JX-BS-F-M4-R-BS10.67 | 0.5-2.0 | 6.75 | 9.91 | 0.76 | 10.67 | 6.73 | 7.75 |
| M4X0.7 | JX-BS-F-M4-R-BS11.94 | 2.0-3.3 | 6.75 | 9.91 | 0.76 | 11.94 | 6.73 | 7.75 |
| M5X0.8 | JX-BS-F-M5-R-BS12.07 | 0.5-3.3 | 7.60 | 10.54 | 0.76 | 12.07 | 7.52 | 8.00 |
| M5X0.8 | JX-BS-F-M5-R-BS14.86 | 3.3-5.7 | 7.60 | 10.54 | 0.76 | 14.86 | 7.52 | 8.00 |
| M6X1.0 | JX-BS-F-M6-R-BS14.73 | 0.7-4.2 | 10.0 | 12.7 | 0.76 | 14.73 | 9.91 | 9.65 |
| M6X1.0 | JX-BS-F-M6-R-BS17.27 | 4.2-6.6 | 10.0 | 12.7 | 0.76 | 17.27 | 9.91 | 9.65 |
| M8X1.25 | JX-BS-F-M8-R-BS17.53 | 0.7-3.8 | 13.5 | 17.4 | 0.89 | 17.53 | 13.46 | 11.94 |
| M8X1.25 | JX-BS-F-M8-R-BS20.45 | 3.8-7.9 | 13.5 | 17.4 | 0.89 | 20.45 | 13.46 | 10.8 |
| M10X1.5 | JX-BS-F-M10-R-BS17.53 | 0.7-3.8 | 13.5 | 17.4 | 0.89 | 17.53 | 13.46 | 11.94 |
| M10X1.5 | JX-BS-F-M10-R-BS20.45 | 3.8-7.9 | 13.5 | 17.4 | 0.89 | 20.45 | 13.46 | 10.8 |
| M12X1.75 | JX-BS-F-M12-R-BS29.21 | 1.6-5.1 | 17.45 | 21.97 | 1.19 | 29.21 | 17.4 | 21.59 |
| M12X1.75 | JX-BS-F-M12-R-BS33.02 | 5.1-8.9 | 17.45 | 21.97 | 1.19 | 33.02 | 17.4 | 21.59 |
| M12X1.75 | JX-BS-F-M12-R-BS36.83 | 8.9-12.7 | 17.45 | 21.97 | 1.19 | 36.83 | 17.4 | 21.84 |

Surface treatment: color zinc, ROHS blue zinc, zinc nickel alloy, can also be produced according to customer requirements

BLIND RIVET NUTS FASTENERS SERIES

Thin Head Open end Knurled Body Blind rivet nuts

Surface treatment: color zinc, ROHS blue zinc, zinc nickel alloy, can also be produced according to customer requirements

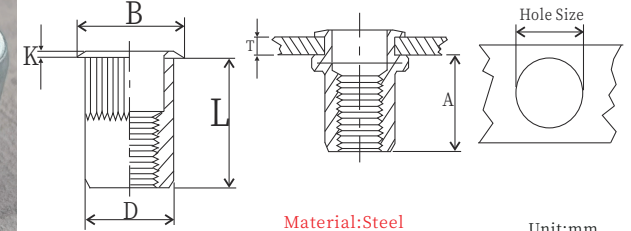

| Thread Size | Part No | Grip Range T | Hole Size $\begin{smallmatrix} +.006 \\ -.000 \end{smallmatrix}$ | B $\begin{smallmatrix} \pm .010 \\ \pm .205 \end{smallmatrix}$ | K $\pm .003$ | L $+ .015$ | D Max | A Max |
|-------------|-------------------|--------------|---------------------------------------------------------------------|-------------------------------------------------------------------|-----------------|---------------|----------|----------|
| #6-32UNC | JX-S-632-R-BS420 | .020-.080 | 17/64(.2656) | .310 | .019 | .420 | .265 | .305 |
| #6-32UNC | JX-S-632-R-BS470 | .080-.130 | 17/64(.2656) | .310 | .019 | .470 | .265 | .305 |
| #8-32UNC | JX-S-832-R-BS420 | .020-.080 | 17/64(.2656) | .310 | .019 | .420 | .265 | .305 |
| #8-32UNC | JX-S-832-R-BS470 | .080-.130 | 17/64(.2656) | .310 | .019 | .470 | .265 | .305 |
| #10-24UNC | JX-S-024-R-BS475 | .020-.130 | 19/64(.2969) | .340 | .019 | .475 | .296 | .315 |
| #10-24UNC | JX-S-024-R-BS585 | .130-.225 | 19/64(.2969) | .340 | .019 | 0.585 | .296 | .315 |
| #10-32UNC | JX-S-032-R-BS475 | .020-.130 | 19/64(.2969) | .340 | .019 | .475 | .296 | .315 |
| #10-32UNC | JX-S-032-R-BS585 | .130-.225 | 19/64(.2969) | .340 | .019 | .585 | .296 | .315 |
| 1/4-20UNC | JX-S-0420-R-BS580 | .027-.165 | 25/64(.3906) | .455 | .022 | .580 | .390 | .380 |
| 1/4-20UNC | JX-S-0420-R-BS680 | .165-.260 | 25/64(.3906) | .455 | .022 | .680 | .390 | .380 |
| 5/16-18UNC | JX-S-0518-R-BS680 | .027-.150 | 17/32(.5312) | .595 | .022 | .690 | .530 | .470 |
| 5/16-18UNC | JX-S-0518-R-BS690 | .150-.312 | 17/32(.5312) | .595 | .022 | .805 | .530 | .425 |
| 3/8-16UNC | JX-S-0616-R-BS690 | .027-.150 | 17/32(.5312) | .595 | .022 | .690 | .530 | .470 |
| 3/8-16UNC | JX-S-0616-R-BS805 | .150-.312 | 17/32(.5312) | .595 | .022 | .805 | .530 | .425 |

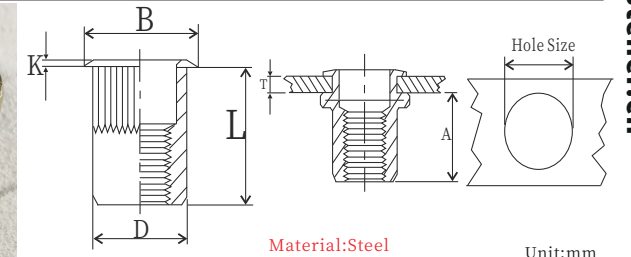

| Thread Size | Part No | Grip Range T | Hole Size $\begin{smallmatrix} +.15 \\ -.000 \end{smallmatrix}$ | B $\begin{smallmatrix} \pm 0.25 \\ \pm 0.67 \end{smallmatrix}$ | K $\pm .008$ | L $+0.38$ | D Max | A Max |
|-------------|-----------------------|--------------|--------------------------------------------------------------------|-------------------------------------------------------------------|-----------------|--------------|----------|----------|
| M4X0.7 | JX-BS-F-M4-R-BS10.67 | 0.5-2.0 | 6.75 | 7.87 | 0.48 | 10.67 | 6.73 | 7.75 |
| M4X0.7 | JX-BS-F-M4-R-BS11.94 | 2.0-3.3 | 6.75 | 7.87 | 0.48 | 11.94 | 6.73 | 7.75 |
| M5X0.8 | JX-BS-F-M5-R-BS12.07 | 0.5-3.3 | 7.60 | 8.64 | 0.48 | 12.07 | 7.52 | 8.00 |
| M5X0.8 | JX-BS-F-M5-R-BS14.86 | 3.3-5.7 | 7.60 | 8.64 | 0.48 | 14.86 | 7.52 | 8.00 |
| M6X1.0 | JX-BS-F-M6-R-BS14.73 | 0.7-4.2 | 10.0 | 11.56 | 0.55 | 14.73 | 9.91 | 9.65 |
| M6X1.0 | JX-BS-F-M6-R-BS17.27 | 4.2-6.6 | 10.0 | 11.56 | 0.55 | 17.27 | 9.91 | 9.65 |
| M8X1.25 | JX-BS-F-M8-R-BS17.53 | 0.7-3.8 | 13.5 | 15.11 | 0.55 | 17.53 | 13.46 | 11.94 |
| M8X1.25 | JX-BS-F-M8-R-BS20.45 | 3.8-7.9 | 13.5 | 15.11 | 0.55 | 20.45 | 13.46 | 10.8 |
| M10X1.5 | JX-BS-F-M10-R-BS17.53 | 0.7-3.8 | 13.5 | 15.11 | 0.55 | 17.53 | 13.46 | 11.94 |
| M10X1.5 | JX-BS-F-M10-R-BS20.45 | 3.8-7.9 | 13.5 | 15.11 | 0.55 | 20.45 | 13.46 | 10.8 |

Surface treatment: color zinc, ROHS blue zinc, zinc nickel alloy, can also be produced according to customer requirements